

airox

*Smart Harmony Of
air & water*

PLATE DIFFUSER

TECHNICAL
DATA
SHEET

Plate 1100

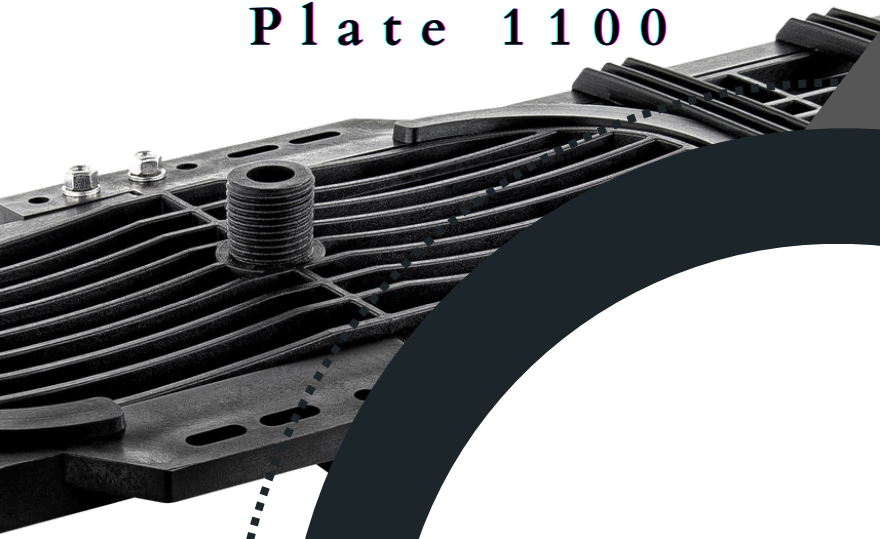

1100mm PLATE DIFFUSER TECHNICAL DATA SHEET

DIMENSIONS

Effective Length	(mm)	1085
Thread	(NPT)	1"-3/4" M
Overall Length	(mm)	1125
Weight	(kg)	3,9
Effective Area	(m ²)	0,016

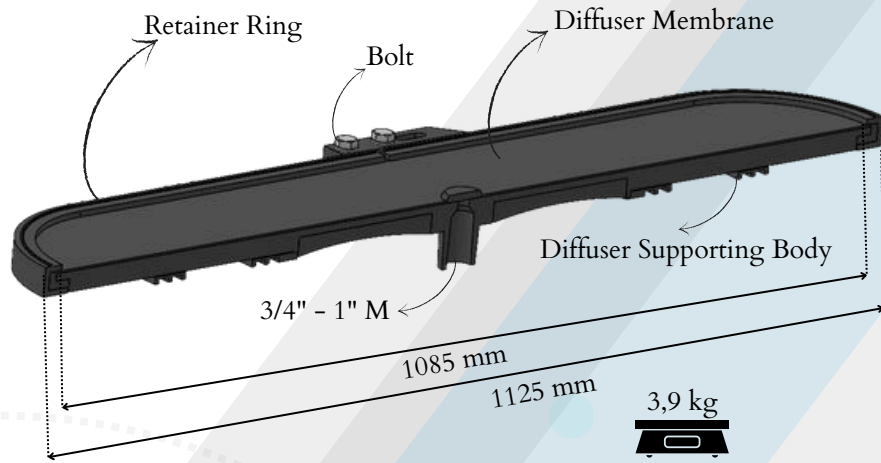

DIFFUSER

1100	Body&Ring	%70 PP, %30 GF
	Membrane	EPDM, Silicone, TPU

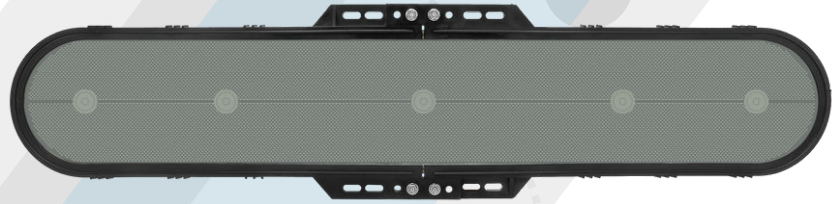

*Logo and color can be change upon request.

MEMBRANE

Test Standarts			EPDM	Silicone	TPU
	Thickness	(mm)	1,90 ± 0,2	1,90 ± 0,2	1,5 ± 0,1
DIN EN ISO 37	Tensile strength	(N/mm ²)	> 12	> 8	> 15
DIN EN ISO 34-1,B-a	Tear strength	(N/mm)	>35	>30	>60
	Capacity*	(Nm ³ /h)	2-32	2-18	2-18
DIN EN ISO 2781	Density	(gr/cm ³)	1,09 ± 0,05	1,06 ± 0,05	1,12 ± 0,05
DIN ISO 7619-1	Hardness	(Shore A)	50 ± 5	55 ± 5	55 ± 5
DIN EN ISO 37	Elongation at break	(%)	>600	>500	>700
	Plasticiser	(%)	20 ± 5	0	0
	Operating Air Temperature	(°C)	5-80	5-100	5-80
	Operating Water Temperature	(°C)	5-40	5-40	5-40

*Check operational data table below for determined airflow rates.



1100mm PLATE DIFFUSER TECHNICAL DATA SHEET

OPERATIONAL DATA

Membrane Type	Mechanical Warranty (year)	Recommended Airflow Rate (Nm ³ /h)	Min-Max Airflow Rate (Nm ³ /h)	Overload (Nm ³ /h)
EPDM	2	10-16	4-32	40
Silicone	2	6-10	4-18	20
TPU	2	6-10	4-18	20

*Performance cannot be guaranteed due to uncertain wastewater characterization and maintenance periods. Mechanical warranty validity is valid under specified operating conditions and maintenance periods.

*The recommended airflow rates at standard operating conditions and design.

*Operating diffusers continuously at max. or min. airflow rate may reduce lifetime or performance. Shutdown of operation is highly recommended for airflow rates lower than the minimum.

*Do not apply overload/maintenance airflow rate (e.g. cleaning) for more than 10 min/day.

*When the air temperature is close to the given max., a lower maximum airflow rate should be used.

PERFORMANCE



*SOTE values depends on the test tank, diffuser density and water height.



airox

GİF PLASTİK SAN. TİC. LTD. STİ.
KAYAPA MAH. ,NERGİZ(530) CAD. ,NO:7,
NİLÜFER/BURSA 16130
TEL : +90 224 443 77 84-85
MOBILE : +90 541 881 00 40
FAX : +90 224 243 34 24
email : info@airox.com.tr



www.airox.com.tr

airox